

Now with up to 40 GHz bandwidth

IQTransmitter

Industry Leading High Bandwidth of 40 GHz - Full & Emulated Dual-Polarization IQTransmitter

Key features :

- Your choice of 40 GHz, 26 GHz or 11 GHz of bandwidth.
- Pattern independent Automatic Bias Control.
- High repeatability and reliability of optimized optical signals.
- Inbuilt narrow linewidth tunable laser.
- Perfect for M-QAM, M-PSK, OFDM and custom modulation formats.
- Intuitive and user-friendly GUI.
- Complete remote control capability.
- Capable of supporting baud rates beyond 64 GBaud.
- Highly customizable to suit your needs.



Providing Complete Solutions to R&D Engineers in Coherent Optical Communications

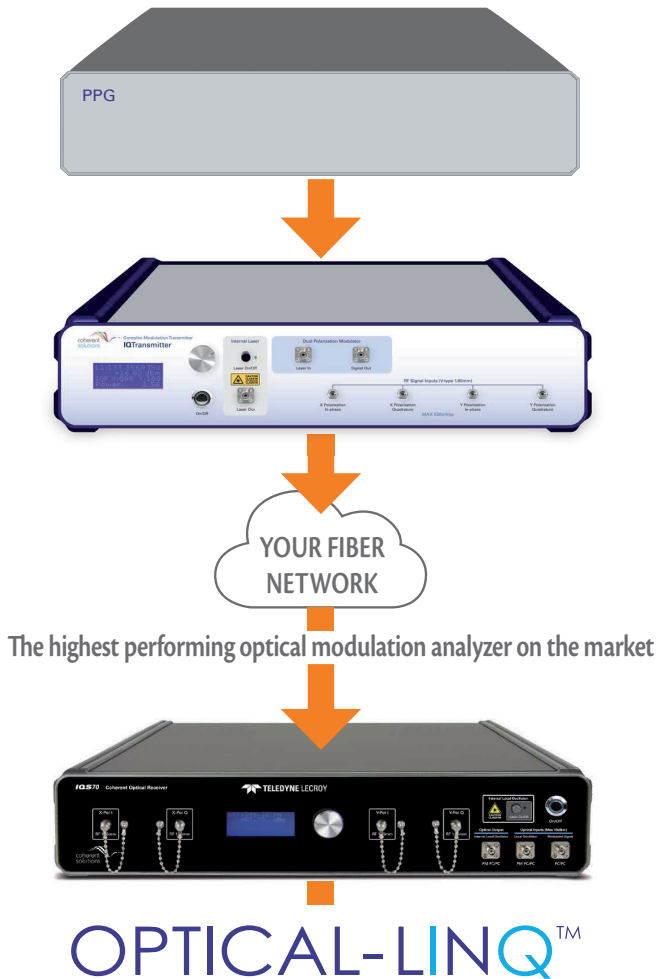

The highest performing optical modulation analyzer on the market

PPG or AWG

Choose the RF electrical signal generator that best suits your requirements.

IQTransmitter

Generation of high bandwidth optical signals encoded with complex modulation formats



Teledyne LeCroy

In partnership with Teledyne LeCroy we offer.

IQS Coherent Receiver

« Gold Standard » Coherent optical receiver with up to 70GHz signal bandwidth.

Optical LinQ

Optical modulation analyzer software.

LabMaster 10Zi-A Oscilloscope

Real-time oscilloscope.

Now with up to 40 ghz bandwidth

IQTransmitter

Introducing the World's Highest Performing & Commercially Available Transmitter - Up to 40GHz

At up to 40 GHz bandwidth, Coherent Solutions' IQTransmitter is the world leader with the highest bandwidth commercially available. The IQTransmitter enables quick and simple generation of phase modulated optical signals in one, simple to use unit.

Even better, the IQTransmitter's unique range of customizations give you unrivalled flexibility and even greater value - Out of the Box.

Generate 16QAM, OFDM & More

The IQTransmitter uses high bandwidth linear RF amplifiers to enable generation of any multi-level optical modulation formats when used with RF Arbitrary Waveform Generators (AWG).

The Ideal 'Golden' Optical Signal Source

Generating and controlling phase modulated optical signals is made easy with the IQTransmitter. Available in three different versions; full dual-polarization, emulated dual-polarization and single polarization, you can select from the most flexible customizations commercially available. The IQTransmitter is referred to as a «Golden» reference optical signal source because of its high repeatability and reliability - Every time you turn it on.

Its unrivalled high bandwidth of 40 GHz (typical) ensures high quality optical signal generation, making it the ideal optical signal source for coherent communications applications.

One User-friendly GUI for all the Instruments

The 'IQSignal-Manager' software enables simple set up and control of the IQTransmitter. IQSignal-Manager automatically discovers any compatible instrument on the Local Area Network so you can monitor and control the IQTransmitter from the comfort of your own desk.

With the vast array of options available, the possibilities are almost endless! Do not hesitate to contact us to help you configure the system that meets your specific needs - 'Complexity will be Made Simple.'

Samples of Signals Generated with the IQTransmitter

56 GBaud 64QAM

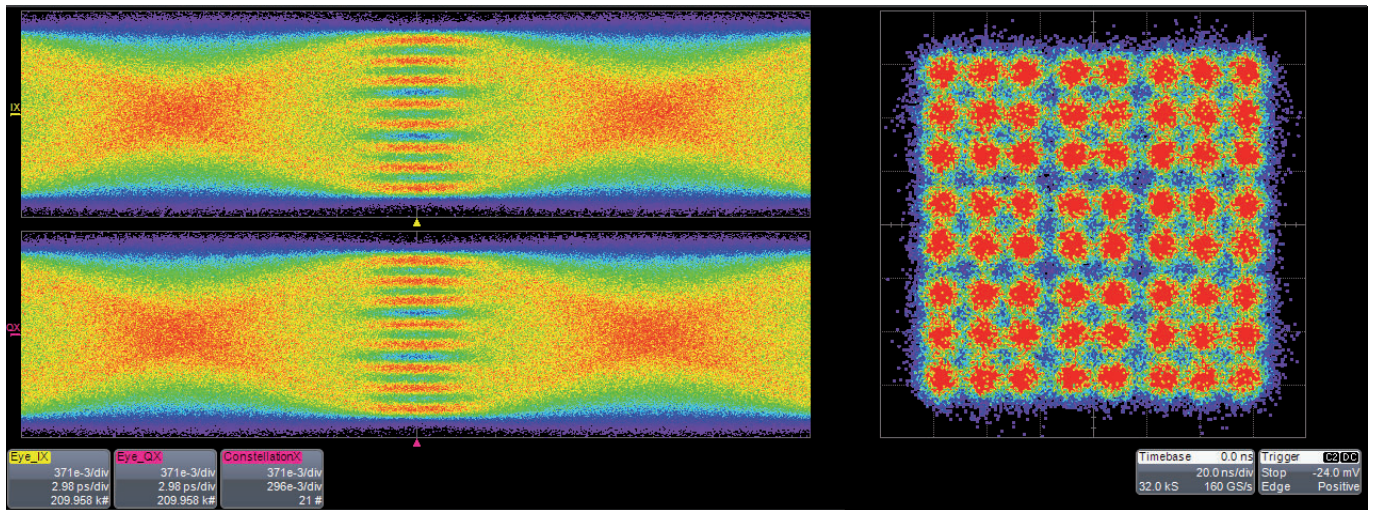

A high quality 64QAM signal at 56 GBaud. EVM ~ 6.8%

High baud rate sample 16QAM at 56 GBaud

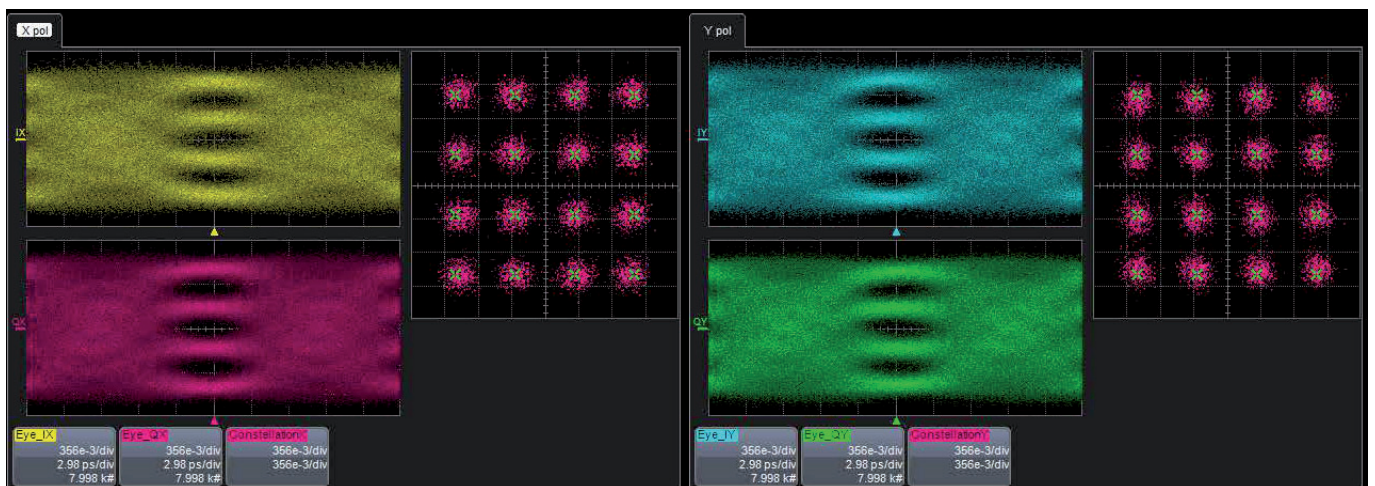

A high quality 16QAM signal at 56 GBaud. EVM ~ 9.5%

DP-QPSK

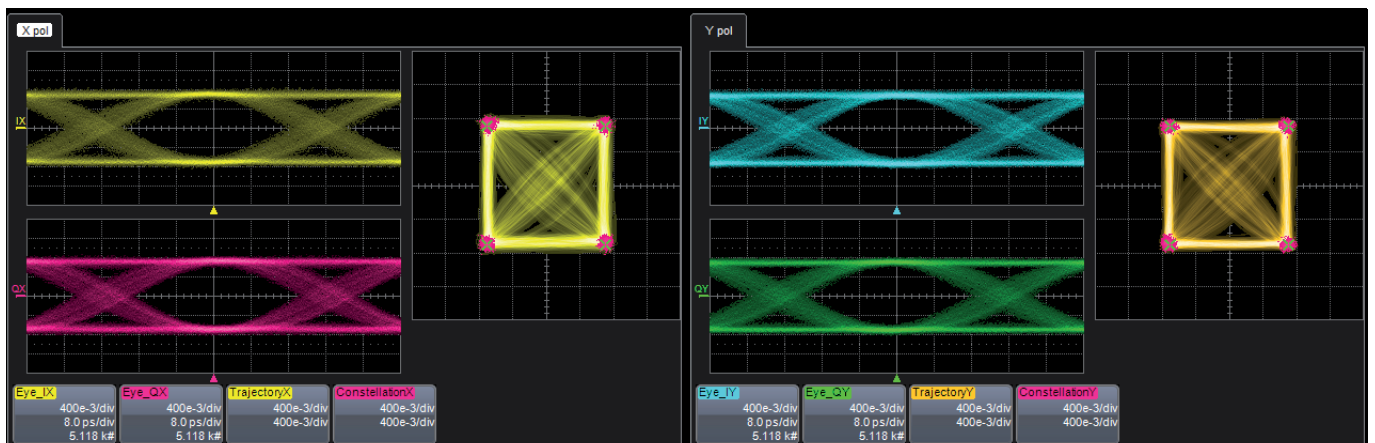

A high quality DP-QPSK signal at 28 GBaud. EVM ~ 5.55%



Samples of Signals Generated with the IQTransmitter

DP-16QAM

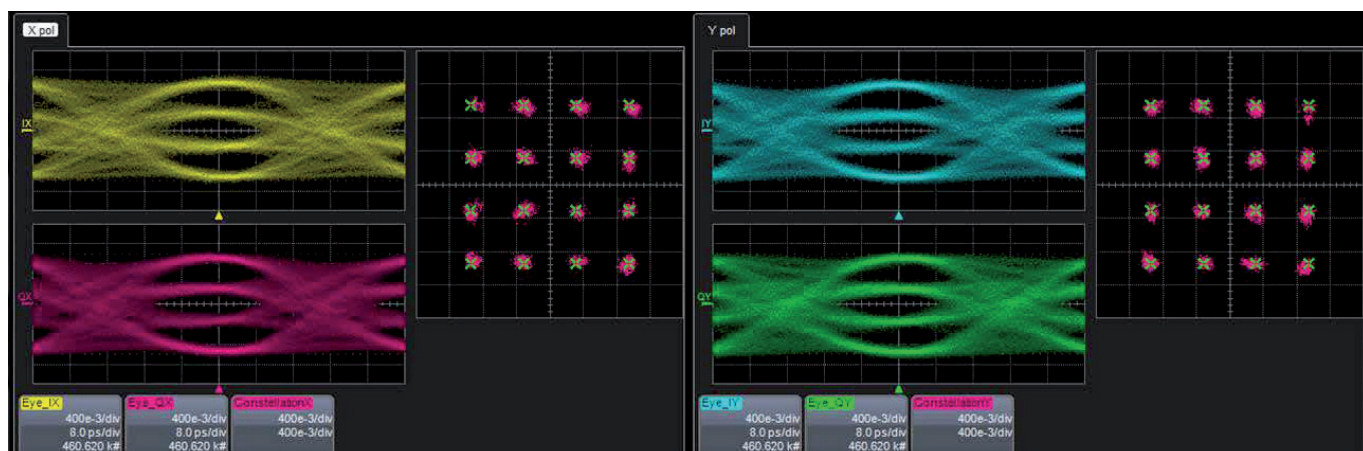

A high quality DP-16QAM signal at 21 GBaud. EVM ~ 5.62%

DP-8QAM

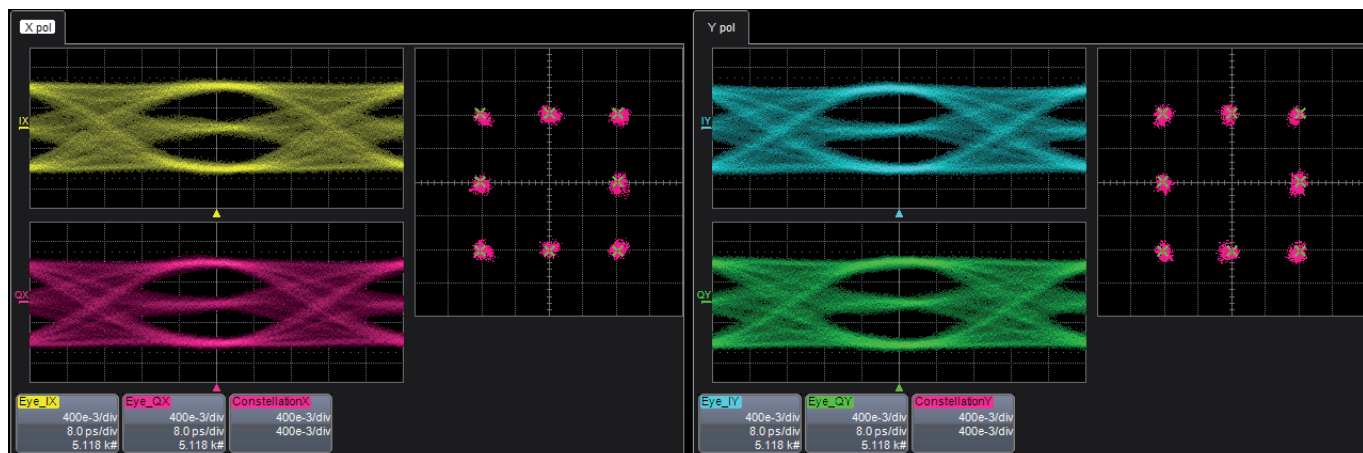

A high quality DP-8QAM signal at 21 GBaud. EVM ~ 6.53%

BPSK

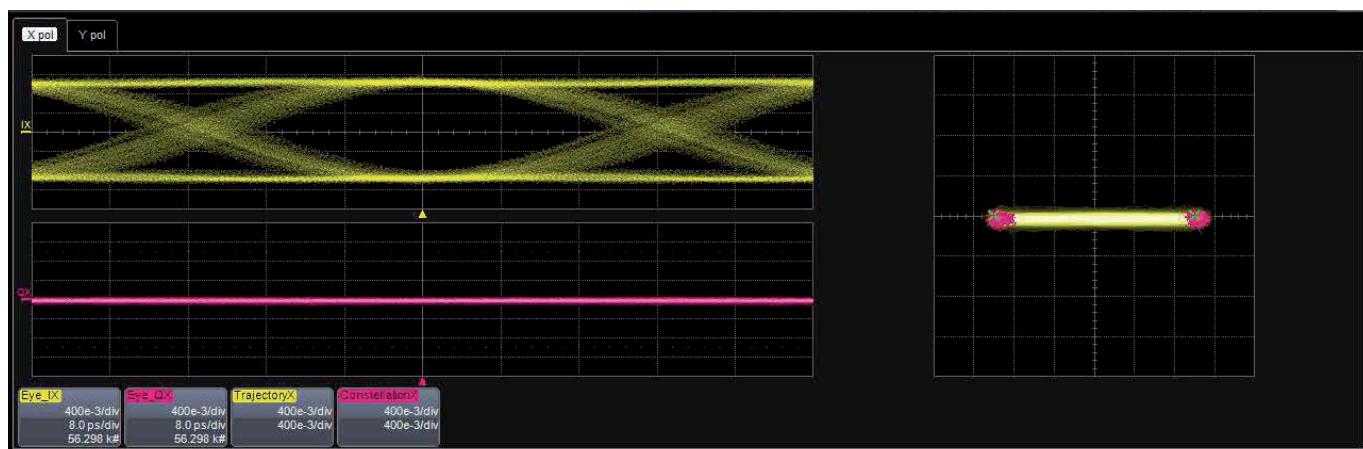

A high quality BPSK signal at 21 GBaud. EVM ~ 7.31%

Example Applications

Optical Communication R&D Engineers need to be able to quickly and cost-effectively generate high-bandwidth optical signals such as 56 GBaud DP-QPSK to support development in fields such as:

- Coherent receiver design verification and testing.
- 200 G, 400 G Coherent System development using multi-levelled modulation formats such as 8QAM, 16QAM and 64QAM.
- Stable and repeatable DP-QPSK or DP-16QAM signal generation for ICR Testing.
- Cost effective DWDM channel loading by modulating multiple carriers

Pattern Independent Automatic Bias Controller

The IQTransmitter is an ideal 'Golden Standard' reference in terms of Repeatability and Reliability. The built-in newly improved Automatic Bias Control (ABC) makes it easy for engineers to quickly generate optimized signals. ABC's high stability ensures that bias points are maintained at the desired location. The ABC allows engineers to work with Arbitrary modulation formats including M-QAM, M-PSK, etc. Our dedicated software for ABC offers complete remote operation capability allowing the user to control the setup even while travelling. These features make the Coherent Solutions' IQTransmitter a superb plug-and-play R&D optical signal generator.



Configure to your needs - Available Options:

- 40 GHz, 26 GHz or 11 GHz system bandwidth
- Full dual polarization, emulated dual polarization & single polarization version
- Adjustable IQ RF delay (external part)
- Internal narrow linewidth, tunable laser - C and/or L band

Talk to our experts to help design your best configuration in accordance with your current set-up, target outcome & budget

Introducing the Full Dual-Polarization IQTransmitter

The full dual-polarization IQTransmitter is a leader in its class; providing more capability, more flexibility and greater ease of use.

For applications requiring loading and transmission of true data, the full dual-polarization IQTransmitter provides capability to transmit independent data on all four tributary RF channels. The full dual-polarization IQTransmitter is compatible with any 4 channel PPG or AWG; and a wide range of options are available to optimize your investment.

IQTransmitter-FDP

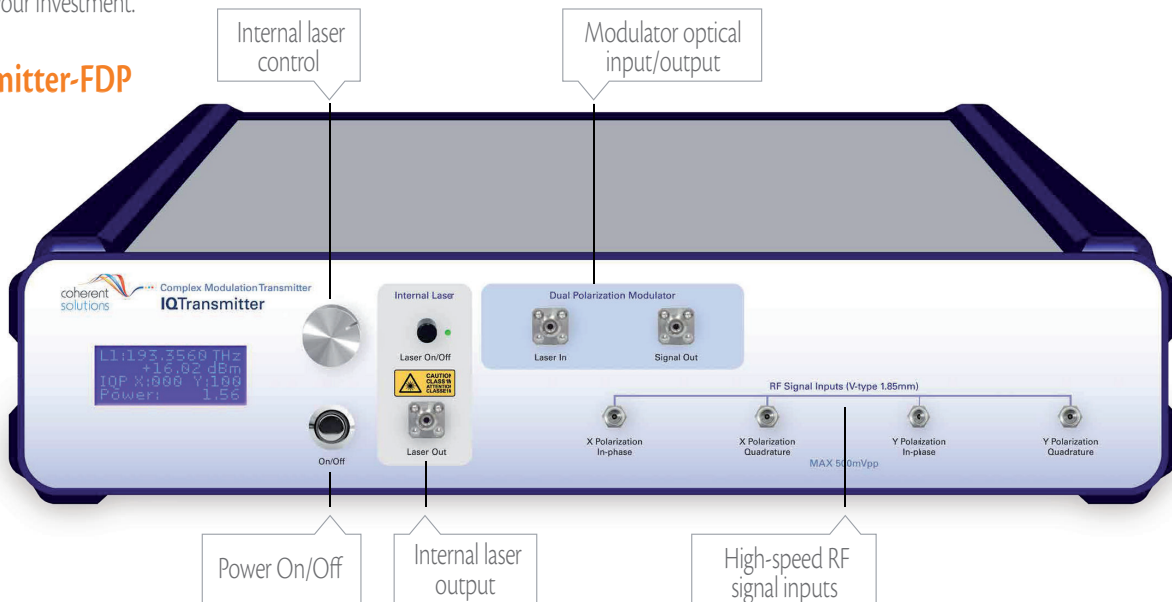

IQTransmitter - FDP Schematic Diagram

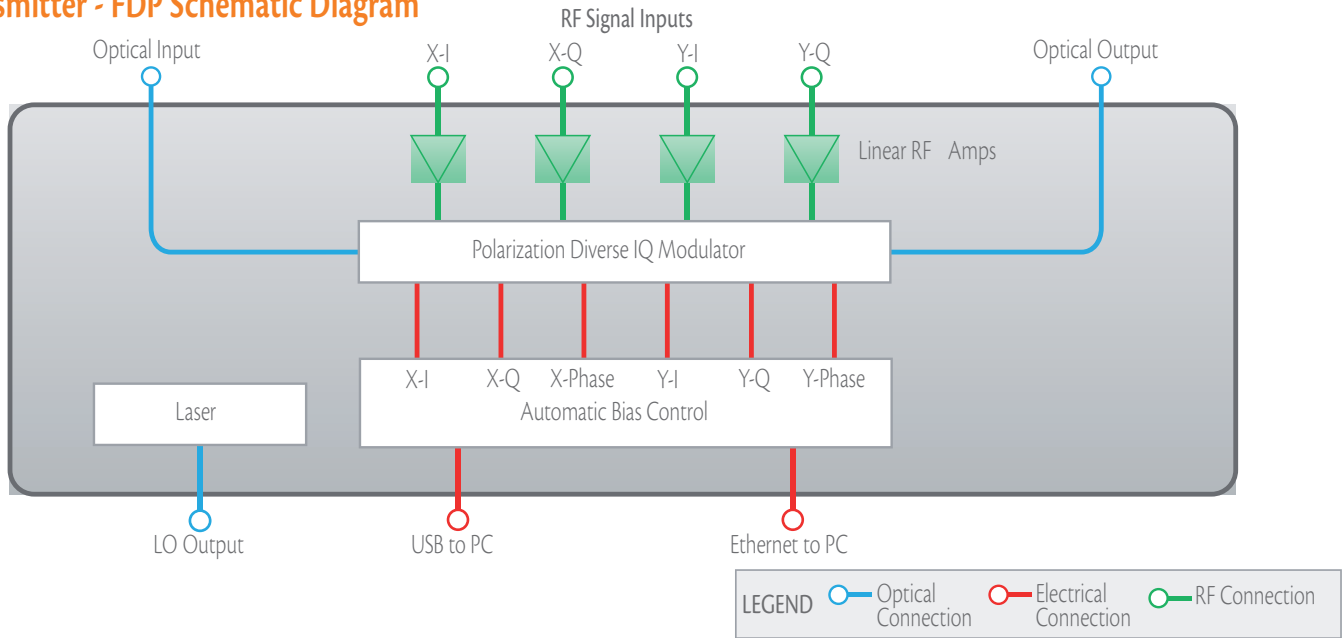

Standard Features

- High bandwidth of 40 GHz (typical)
- 4 x 1.85 mm high speed RF signal inputs
- Automatic Bias Control via the dedicated software controller
- Built-in C-band narrow linewidth tunable laser
- Automatic software modulator bias control
- High bandwidth linear RF amplifiers

Available Options

Bandwidth

- Choose between 40 GHz, 26 GHz or 11 GHz of system bandwidth

CL

- Choose C and / or L band built-in tunable laser with < 100 kHz linewidth and up to 15 dBm of output power

Versatile Configuration Options for FDP

Full Dual-Pol M-QAM, M-PSK & Arbitrary Signal Generation

When used in conjunction with an appropriate 4 channel AWG

(or two dual-channel synchronized AWG's), fully independent Dual-Pol M-QAM

optical signals can be synthesized. This enables the R&D Engineer to generate optical

data streams that reflect current state-of-art long-haul optical communication systems.

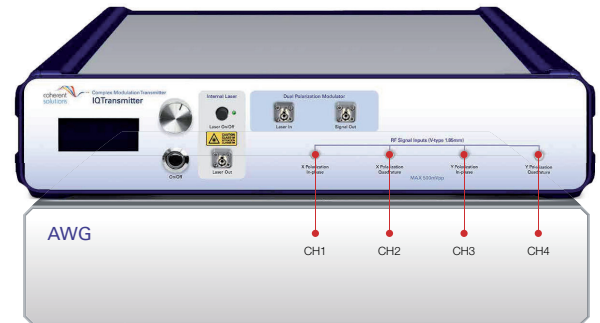

16QAM

$Q_x(\text{Ch.1})$

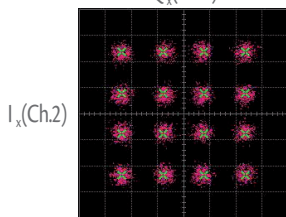

x-pol

$Q_y(\text{Ch.3})$

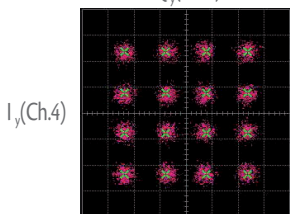

y-pol

8QAM

$Q_x(\text{Ch.1})$

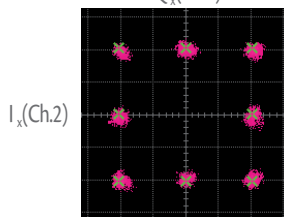

x-pol

$Q_y(\text{Ch.1})$

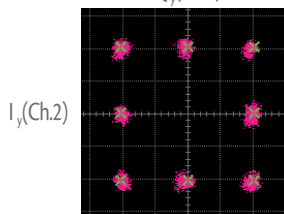

y-pol

QPSK

$Q_x(\text{Ch.1})$

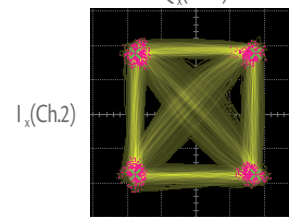

x-pol

$Q_y(\text{Ch.3})$

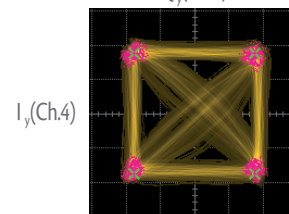

y-pol

IQTransmitter - FDP Schematic Diagram

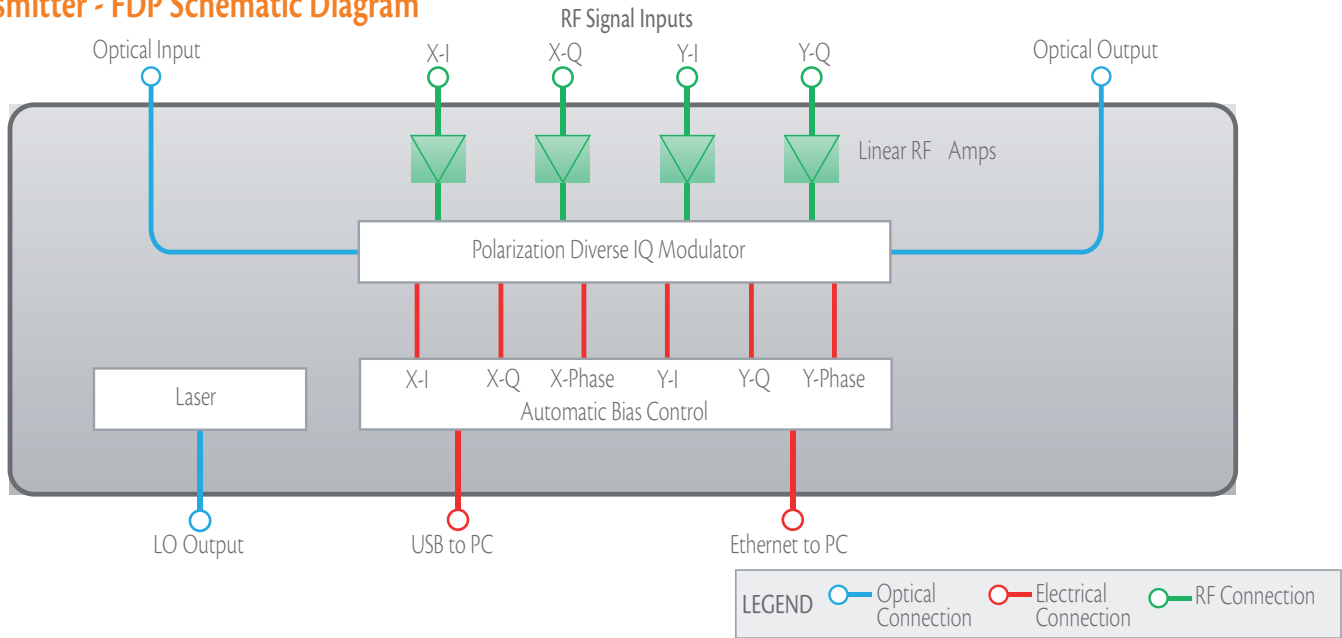

Standard Features

- High bandwidth of 40 GHz (typical)
- 4 x 1.85 mm high speed RF signal inputs
- Automatic Bias Control via the dedicated software controller
- Built-in C-band narrow linewidth tunable laser
- Automatic software modulator bias control
- High bandwidth linear RF amplifiers

Available Options

Bandwidth

- Choose between 40 GHz, 26 GHz or 11 GHz of system bandwidth

CL

- Choose C and / or L band built-in tunable laser with < 100 kHz linewidth and up to 15 dBm of output power

Versatile Configuration Options for FDP

Full Dual-Pol M-QAM, M-PSK & Arbitrary Signal Generation

When used in conjunction with an appropriate 4 channel AWG

(or two dual-channel synchronized AWG's), fully independent Dual-Pol M-QAM

optical signals can be synthesized. This enables the R&D Engineer to generate optical

data streams that reflect current state-of-art long-haul optical communication systems.

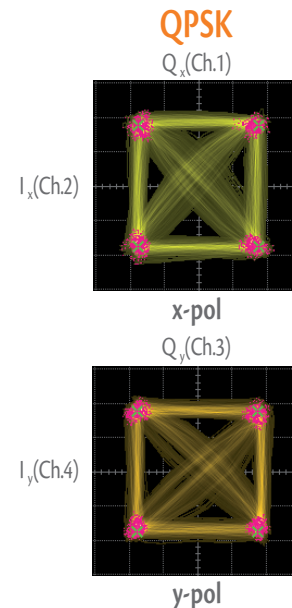
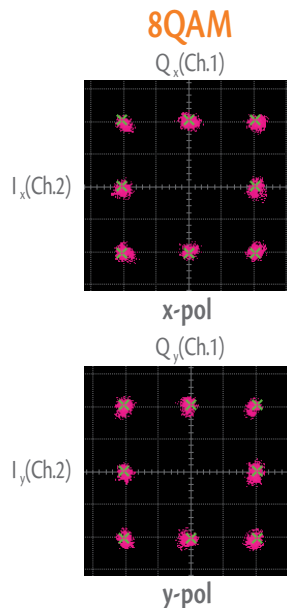
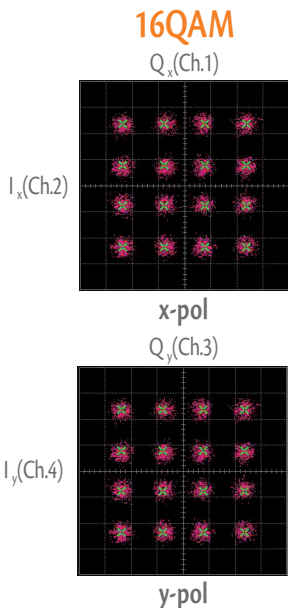
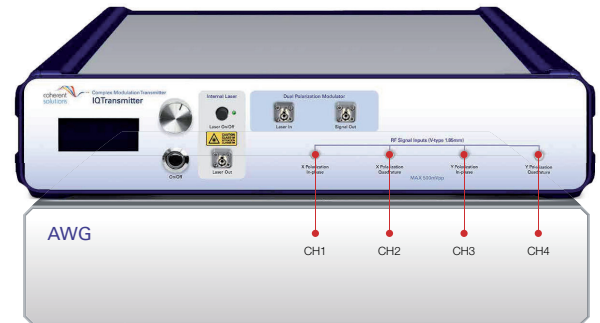

Introducing the Emulated Dual-Polarization IQTransmitter

Emulated dual-polarization generation is a cost-effective solution which enables you to generate dual-polarization phase modulated signals with just two RF input channels.

The Emulated Dual-Polarization IQ Transmitter can generate dual-polarization phase modulated signals by optically polarization multiplexing a delayed copy of the single-polarization modulated signal.

The two RF inputs can be driven by differential outputs of a single channel data source. So with the emulated dual-polarization generator you can create DP-QPSK signals using two differential outputs of a single channel PPG - significantly reducing costs in applications which do not require independent data.

IQTransmitter-EDP

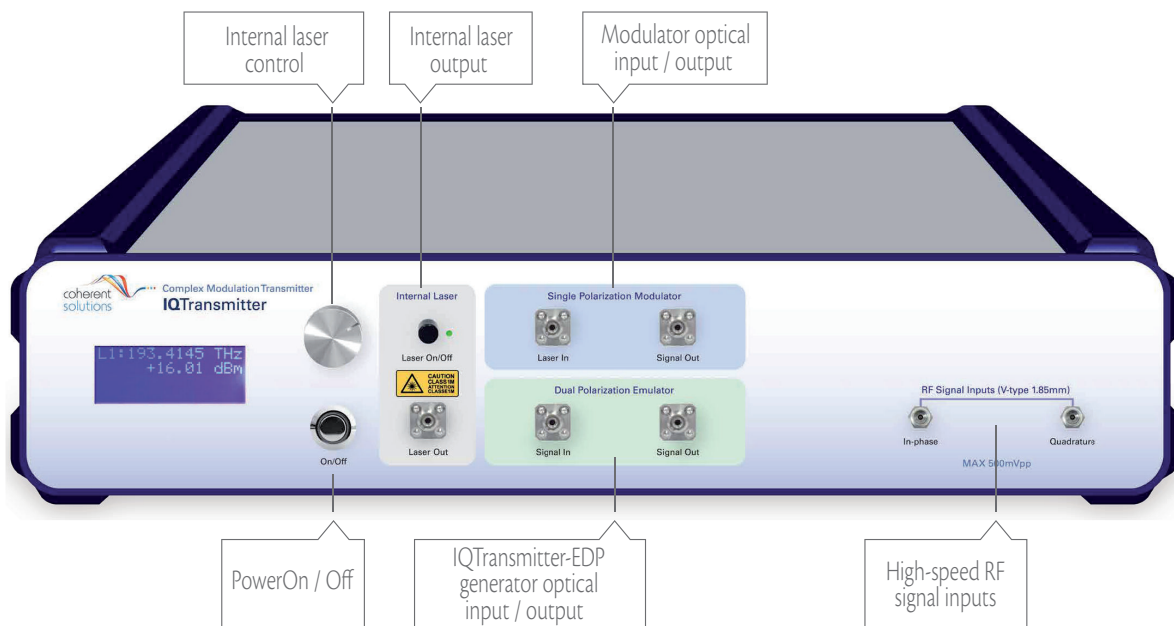

IQTransmitter - EDP Schematic Diagram

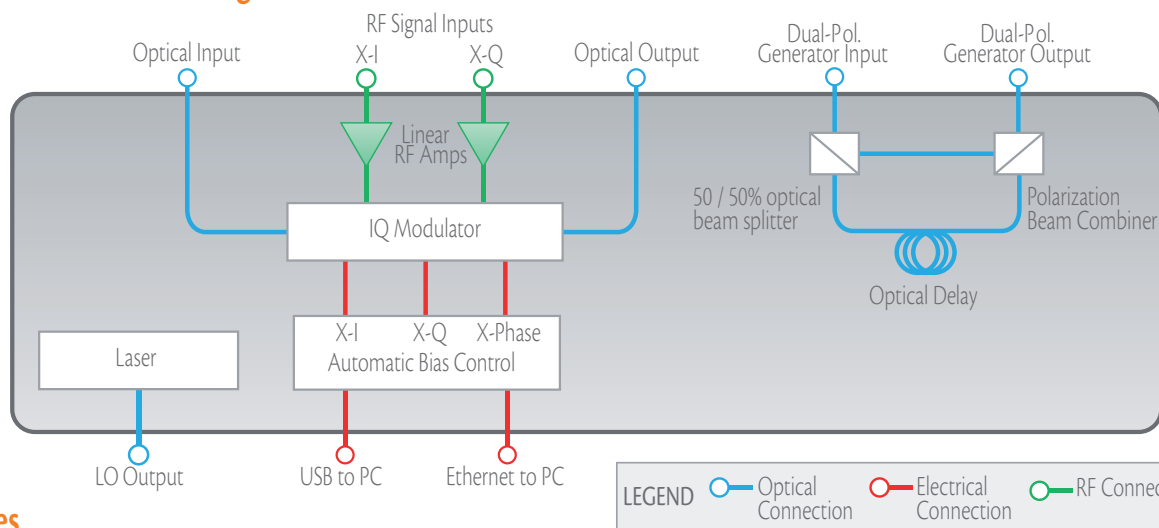

Standard Features

- Emulated dual-polarization generator.
- High bandwidth of 40 GHz (typical).
- 2 x 1.85 mm high speed RF signal inputs.
- Automatic Bias Control via the dedicated software controller.
- Built-in C-band narrow linewidth tunable laser.
- Manual hardware modulator bias controls.
- High bandwidth linear RF amplifiers.

Available Options

Bandwidth

- Choose between 40 GHz, 26 GHz or 11 GHz of system bandwidth

ADL

- Choose the adjustable RF delay option when control of the skew between RF inputs is required. The ADL is supplied as an external part.

Versatile Configuration Options for EDP

Emulated Dual-Pol M-QAM, M-PSK & Arbitrary Signal Generation

For the majority of R&D applications it is not essential for two polarization states to contain different data, e.g. coherent receiver R&D. In such applications the EDP IQTransmitter offers a more cost-effective solution. If you need high-quality, high-bandwidth DP-QPSK optical signals, but don't need independent data on the X & Y polarizations, use a PPG to generate your signals. With the addition of an external delay-line, full control of the skew between I & Q channels in each polarization can be achieved.

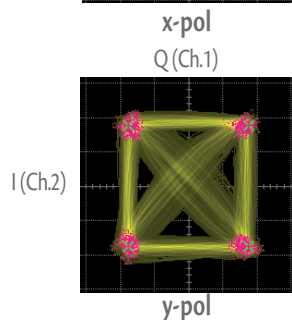
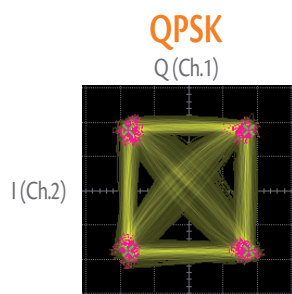
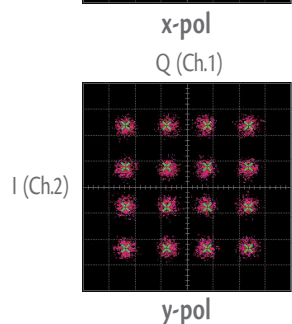
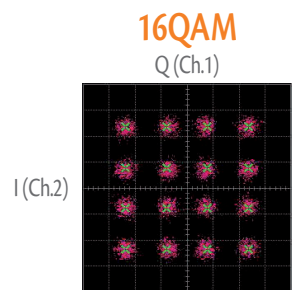
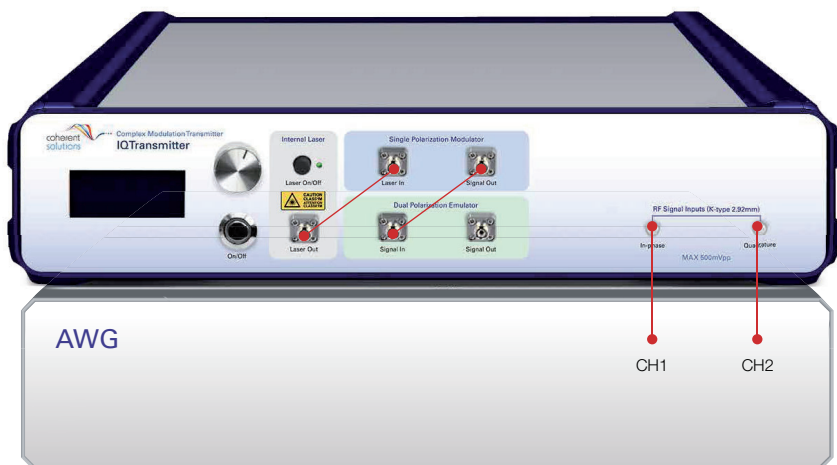

Intuitive GUI

Intuitive 'IQSignal-Manager' for More Flexibility in Modulator Bias Control

The 'IQSignal-Manager' is the dedicated bias control software to adjust individual bias settings or select automatic optimization, which lets you quickly and effortlessly generate optimized QPSK or 16QAM signals.

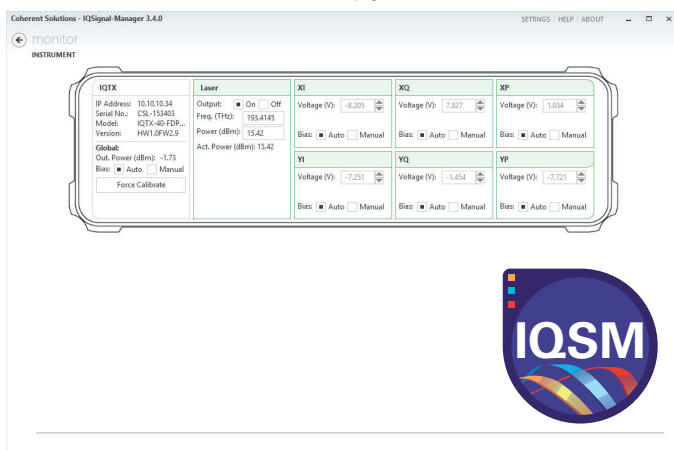

Technical Specifications

IQ Transmitter - Modulator Specifications

Full Dual-Polarization

	11 GHz	26 GHz	40 GHz
Modulator Type	Dual-polarization LiNbO ₃ IQ Modulator		
Wavelength Range	1530 - 1610 nm		
DC Extinction Ratio	> 20 dB		
Maximum Optical Input Power	16 dBm		
Input Optical Connector Type	PM FC/PC		
Output Optical Connector Type	PM FC/PC		
RF Bandwidth	11 GHz (typical)	> 23 GHz, 26 GHz (typical)	40 GHz (typical)
Number of RF Inputs	4		
RF Connector Type	RF 2.92 mm Female	RF 1.85 mm Female	
RF Return Loss	-15 dB (typical)		
Maximum RF Input Voltage	500 mV		

Dual Polarization Emulator

Insertion Loss	<2 dB
----------------	-------

Single Polarization

	Single-polarization LiNbO ₃ IQ Modulator		
Wavelength Range	1530 - 1570 nm		1530 - 1610 nm
Optical Return Loss	> 30 dB		T.B.D.
RF Bandwidth	11 GHz (typical)	> 22 GHz, 26 GHz (typical)	40 GHz (typical)
Number of RF Inputs	2		

ABC - Automatic Bias Control

- ABC is an integrated function in the 'IQSignal-Manager' software. IQSignal-Manager allows individual adjustment of I, Q and IQ phase offset and also can optimize the bias points automatically

Supported modulator types	Single & Dual Pol. IQ Mach Zehnder
Supported modulation formats	Any modulation format
Bias control options	Automatic locking and individual manual bias
Maximum bias voltage range	28 V
Number of bias control channels	6
Startup time until settled	< 3 minutes, < 1minute typical
Quadrature error	Averaged mean < ± 0.3° Standard deviation > 24 hours: < 2°
ABC Impact on EVM	< 1%

All specifications subject to change without notice.

Product Selection Guide

Coherent Solutions understands that everyone's needs are unique. The IQTransmitter is highly customizable and can be upgraded with various options to suit your specific requirements.

A selection of common configurations are presented in the comparison table to help you make the right choice.

IQTransmitter Option Configuration	DP Emulation with 2 RF channels	Independent data on 4 RF channels	QPSK, OOK, BPSK generation	M-QAM, OFDM generation	In built C and/or L band laser	SW Bias Control with ABC
EDP	✓		✓	✓		✓
EDvP-CL	✓		✓	✓	✓	✓
FDP		✓	✓	✓		v
FDP-CL		✓	✓	✓	✓	✓

Options

11 GHz, 26 GHz, 40 GHz Bandwidth

- System bandwidth

EDP - Emulated Dual Polarization Version

- 2 RF inputs (I & Q) which are optically multiplexed to produce I_x, Q_x, I_y, Q_y
- C-band operation
- Internal C-band narrow linewidth tunable laser

FDP - Full Dual Polarization Version

- Provides fully independent modulation of I_x, Q_x, I_y, Q_y
- Linear internal RF amplifiers, suitable for M-QAM and M-PSK modulation formats
- C+L band operation
- Internal C-band narrow linewidth tunable laser

ADL - Adjustable IQ RF Delay

- Manual RF delay adjustment when skew control between RF inputs is required
- This is of use when a single-channel PPG is used (data & data)
- The ADL option is delivered as an external part

Adjustable Delay Range	100 ps
Fixed Delay Offset	400 ps at minimum adjustable delay setting
Phase Shift Per Shaft Turn	1.5° / GHz
Time Delay Per Shaft Turn	4.4 ps
RF Bandwidth	26 GHz

CL - Built-in Tunable Laser ^a

A C-band tunable laser is built-in as standard option. You can upgrade to increase its wavelength range to C & L-band (with the -CL option). You can also remove the built-in laser (with the -NL option), for an extra cost reduction.

Wavelength Tuning	C-band	C & L-band
Operating wavelength range (nm)	1527.605 - 1567.132	1527.605 - 1608.760
Operating frequency range (THz)	191.30 - 196.25	186.35 - 196.25
Laser type	Thermally tuned External Cavity Diode Laser (ECDL)	
Frequency tuning resolution (wavelength) ^b	1 MHz (~0.01 pm)	
Tuning time	< 25 s	

Optical Power		
Maximum optical output power	15.4 dBm	12.2 dBm
Minimum optical output power	6.6 dBm	3.4 dBm
Optical power uncertainty after calibration ^b	± 0.4 dB	
Power stability over 24 hours	± 0.03 dB typ.	
Power flatness over entire wavelength range	± 0.25 dB	
Output power tuning resolution	0.01 dB	
Power monitoring	Built-in	
Polarization extinction ratio at the PM fiber output	> 20 dB	
Relative intensity noise RIN (for 13 dBm)	-145 dB/Hz (10 MHz - 40 GHz)	

Spectral Characteristics	
Linewidth (FWHM), instantaneous ^c	< 100 kHz (25 kHz typ.)
Side-mode suppression ratio	40 dB (55 dB typ.)
Relative frequency accuracy ^d	± 1.5 GHz
Absolute frequency accuracy ^d	± 2.5 GHz
Frequency stability (wavelength) over 24 hours ^d	± 0.3 GHz (± 3 pm)

Notes: ^aSpecifications are valid at 23 °C ± 3 °C. ^bAt maximum output power. ^cThe laser uses a small FM dithering as part of its wavelength-locking mechanism. The instantaneous linewidth is measured in 1 ms (integration time). ^dVaries slightly according to wavelength.

General Characteristics

Dimensions W x D x H	440 x 390 x 97 mm 17.3 x 15.4 x 3.8 inches
Weight	6 kg 13.2 lbs
PC Interface	USB 2.0, Ethernet
Operating System Requirements	Windows 7, 8 or 10 (32 or 64 bit)
Power Supply	100 - 240 V, 50 - 60 Hz, 70 W
Operating Temperature Range	+5 °C to +45 °C 41 °F to 113 °F

All specifications subject to change without notice.

Product Warranty



All Coherent Solutions' products come with a standard 3 year warranty.

